

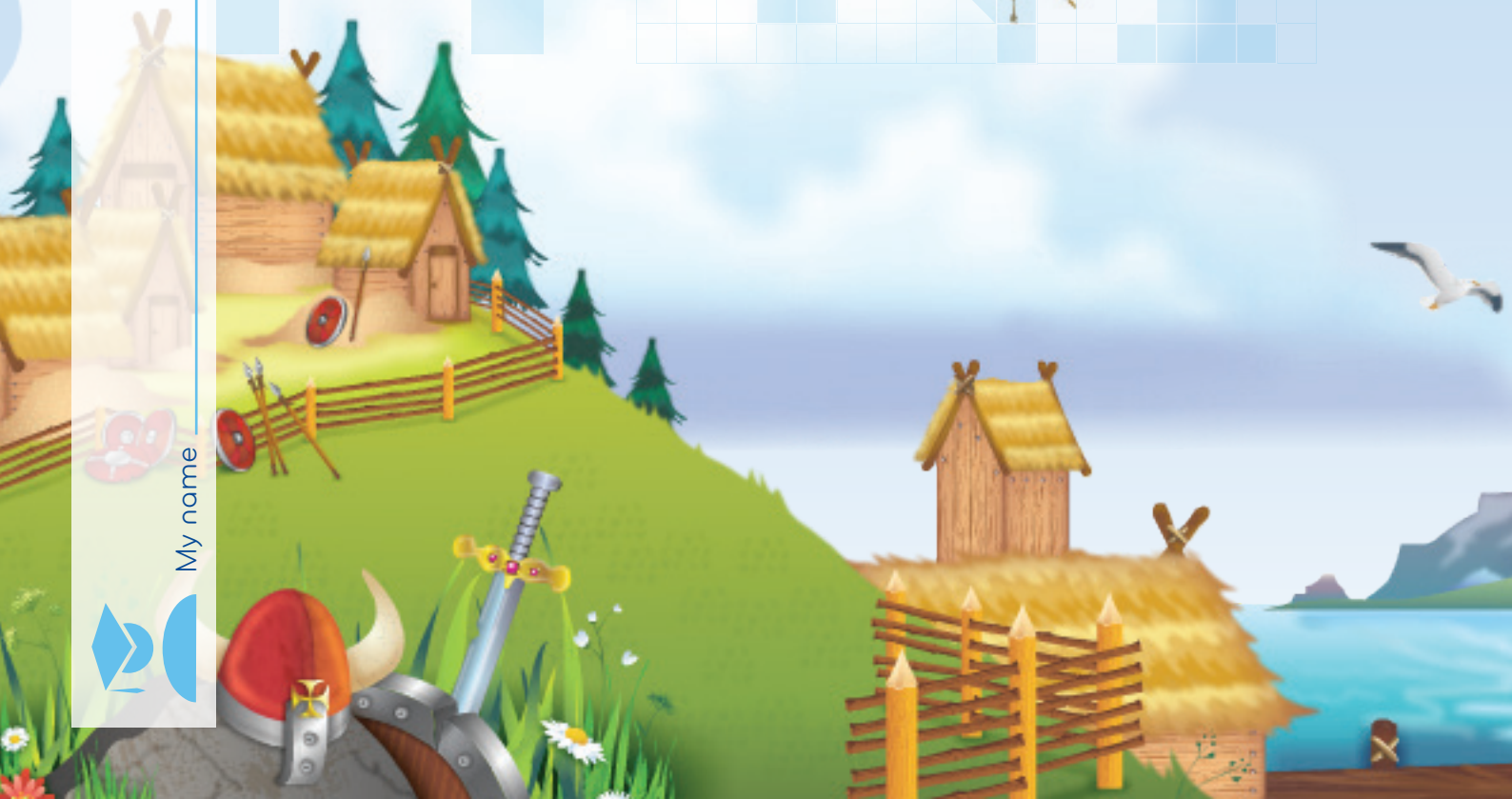

Length, Perimeter and Area

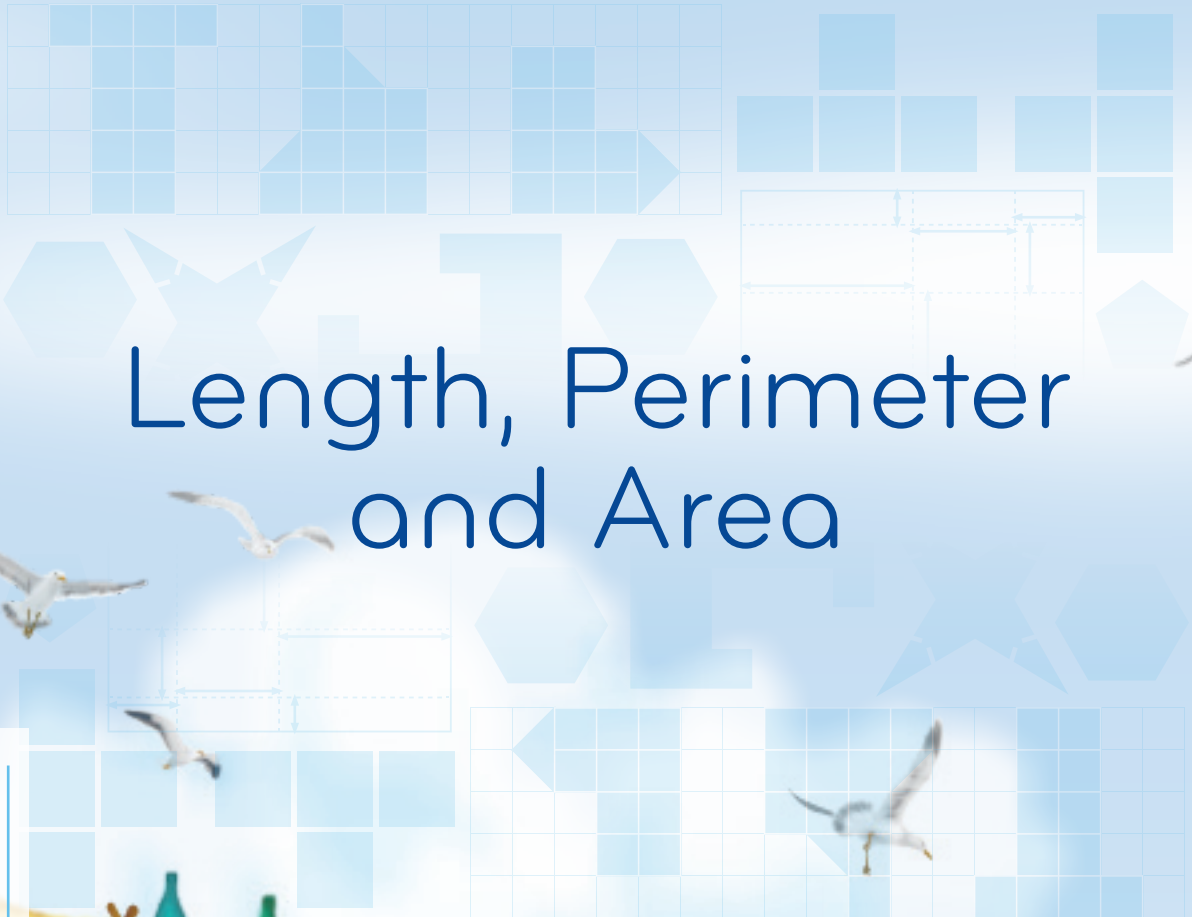

My name



Copyright © 2009 3P Learning. All rights reserved.

First edition printed 2009 in Australia.

A catalogue record for this book is available from 3P Learning Ltd.

ISBN 978-1-921860-62-1

Ownership of content The materials in this resource, including without limitation all information, text, graphics, advertisements, names, logos and trade marks (Content) are protected by copyright, trade mark and other intellectual property laws unless expressly indicated otherwise.

You must not modify, copy, reproduce, republish or distribute this Content in any way except as expressly provided for in these General Conditions or with our express prior written consent.

Copyright Copyright in this resource is owned or licensed by us. Other than for the purposes of, and subject to the conditions prescribed under, the Copyright Act 1968 (Cth) and similar legislation which applies in your location, and except as expressly authorised by these General Conditions, you may not in any form or by any means: adapt, reproduce, store, distribute, print, display, perform, publish or create derivative works from any part of this resource; or commercialise any information, products or services obtained from any part of this resource.

Where copyright legislation in a location includes a remunerated scheme to permit educational institutions to copy or print any part of the resource, we will claim for remuneration under that scheme where worksheets are printed or photocopied by teachers for use by students, and where teachers direct students to print or photocopy worksheets for use by students at school. A worksheet is a page of learning, designed for a student to write on using an ink pen or pencil. This may lead to an increase in the fees for educational institutions to participate in the relevant scheme.

Published 3P Learning Ltd

For more copies of this book, contact us at: www.3plearning.com/contact

Designed 3P Learning Ltd

Although every precaution has been taken in the preparation of this book, the publisher and authors assume no responsibility for errors or omissions. Neither is any liability assumed for damages resulting from the use of this information contained herein.

Series E – Length, Perimeter and Area

Contents

Topic 1 – Units of length (pp. 1–10)

Date completed

- metres and centimetres _____
- length and decimal notation _____
- millimetres _____
- kilometres _____
- convert it – *apply* _____

Topic 2 – Perimeter (pp. 11–17)

- measuring shapes _____
- calculating perimeter _____
- perimeter word problems _____
- perimeter challenges – *solve* _____
- harder perimeter challenges – *solve* _____

Topic 3 – Area (pp. 18–23)

- square centimetres _____
- square metres _____
- investigating area and perimeter _____
- area challenges 1 – *apply* _____
- area challenges 2 – *apply* _____

Series Author:

Nicola Herring

Please note:

These pages have been designed to print to 'shrink to printable area' as this is a common default setting on many computers. There may be minor discrepancies with measurements as individual printers and photocopiers print to slightly different proportions.

Units of length – metres and centimetres

We use metres, centimetres and millimetres regularly in everyday life. There are 100 centimetres in 1 metre. Another way to think about this relationship is that 1 centimetre is one hundredth of a metre.

$$100 \text{ cm} = 1 \text{ m} \quad 1 \text{ cm} = \frac{1}{100} \text{ m or } 0.01 \text{ m} \quad \text{So } \frac{1}{2} \text{ m} = 50 \text{ cm} = 0.5 \text{ m}$$

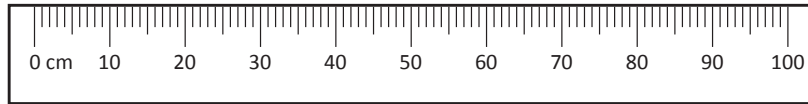

1 Convert each metre measurement into centimetres:

a $2 \text{ m} = \boxed{} \text{ cm}$ **b** $4 \text{ m} = \boxed{} \text{ cm}$ **c** $\frac{1}{4} \text{ m} = \boxed{} \text{ cm}$
d $9 \text{ m} = \boxed{} \text{ cm}$ **e** $\frac{1}{2} \text{ m} = \boxed{} \text{ cm}$ **f** $1\frac{1}{4} \text{ m} = \boxed{} \text{ cm}$

2 Convert each centimetre measurement to metres:

a $10 \text{ cm} = \boxed{} \text{ m}$ **b** $30 \text{ cm} = \boxed{} \text{ m}$ **c** $90 \text{ cm} = \boxed{} \text{ m}$
d $50 \text{ cm} = \boxed{} \text{ m}$ **e** $75 \text{ cm} = \boxed{} \text{ m}$ **f** $80 \text{ cm} = \boxed{} \text{ m}$

3 Estimate and measure three things that fit in each category:

	Estimate in cm	Measure in cm
a About $\frac{1}{2}$ metre		
b About $\frac{3}{4}$ metre		
c About 1 metre		

4 Match these objects to their correct measurement by connecting them with a line:



37 m

45 cm

5 cm

83 cm

1 m 15 cm

12 cm

Units of length – metres and centimetres

5 Measure the length of the lines below using a ruler. Write each length in centimetres, to the nearest centimetre.

a  cm

b  cm

c  cm

6 Answer these questions about the lines above:

a How much longer is line **b** than line **c**? cm

b What would the length of line **b** be if it was 3 cm shorter? cm

c What would the length of line **c** be if it was 9 cm longer? cm

7 Draw lines for the following measurements. Make sure you start each line on the dot.

a 14 cm •

b $\frac{1}{2}$ cm •

c $8\frac{1}{2}$ cm •

8 Work with a partner to measure the following parts of your body with a tape measure. Label your measurements to the nearest centimetre in the boxes.

a Across your shoulders. cm

c Around one ankle. cm

e From your foot to the top of your thigh. cm

g From the top of your forehead to your chin. cm

b Around your head. cm

d Around one wrist. cm

f Around one knee. cm

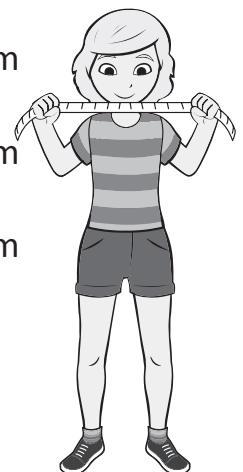

Units of length – length and decimal notation

When we measure things that are in metres and centimetres it is useful to record such lengths in decimal notation. Remember that $1 \text{ cm} = \frac{1}{100} \text{ m}$. This can be written as 0.01 m. So if we measure something that is 1 metre and 36 centimetres long, we would write it like this:

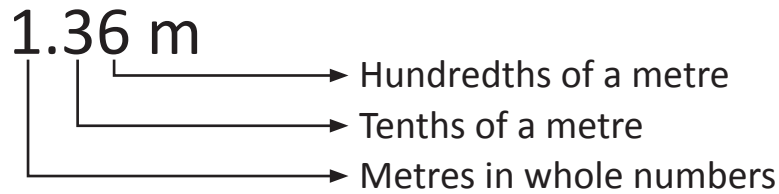

1 Write the measurements in decimal form:

- a 1 metre 69 centimetres = m b 2 metres 91 centimetres = m
c 3 metres 23 centimetres = m d 34 centimetres = m
e 9 metres 4 centimetres = m f 5 metres 9 centimetres = m

2 Write these centimetres as metres using decimal notation:

- a 416 cm = m b 319 cm = m c 567 cm = m
d 607 cm = m e 510 cm = m f 4 cm = m

3 Write these measurements as centimetres:

- a 9.34 m = cm b 3.45 m = cm c 6.07 m = cm
d 5.47 m = cm e 0.94 m = cm f 9.51 m = cm

4 Draw lines for the following measurements. Make sure you start each line on the dot and keep each line parallel to the top of the page.

- a 0.07 m •
b 0.14 m •
c 0.02 m •

Units of length – length and decimal notation

- 5 Charlotte thinks that how far you can jump depends on your height. Do you think she is right? Work in a group of four to complete this table. You will need a tape measure and a space to do long jump. First measure each person's height and record it under their name in decimal notation. Then each person jumps as far as they can. Measure this distance and record it under their height in decimal notation.

Name				
Height				
Long jump				

a Order the names in your group from tallest to shortest:

b Order the long jumps from longest to shortest by writing the names:

c Do you agree with Charlotte? Why or why not?

- 6 Find the lines that connect to make these lengths: 1 m, 2 m and 3 m. Show you have found them by tracing over lines that connect in different colours. To start you off, the first length has been done for you.

a 1 m = _____

b 2 m = _____

c 3 m = _____

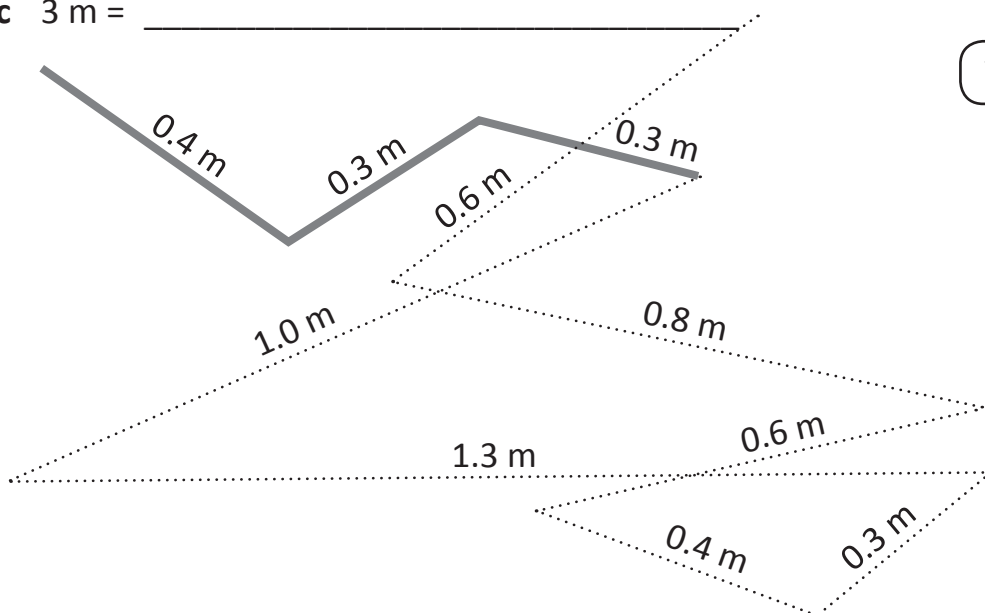

You can use a calculator.



Units of length – length and decimal notation

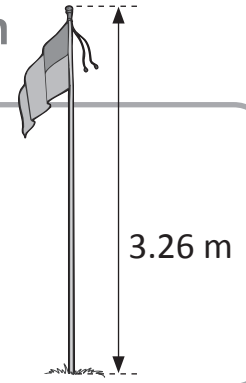

We can use decimal notation to record lengths.

This flag pole is 326 centimetres tall and can be written as 3 metres and 26 centimetres or 3.26 metres in decimal notation.

7 Match the following measurements. The first one has been done for you.

1 m 65 cm	267 cm	9.87 m
2 m 67 cm	987 cm	2.61 m
1 m 69 cm	261 cm	1.65 m
9 m 87 cm	169 cm	1.69 m
2 m 61 cm	165 cm	2.67 m

Connections: A line connects '1 m 65 cm' to '165 cm'. Another line connects '165 cm' to '1.65 m'.

8 Record the total length of both lines in each question in decimal notation:

a

m

b

m

c

m

Units of length – length and decimal notation

9 In this activity, you are going to make a paper aeroplane to fly and mark the distance it has flown. You will need one sheet of A4 paper, a ball of string and a metre ruler.

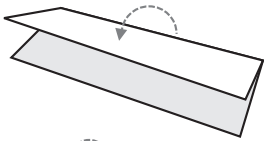

1 Fold the sheet of A4 paper in half lengthwise. Crease the folded end. Unfold the paper and lay it on a flat surface.

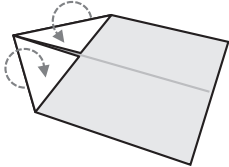

2 Fold the right top corner to the centre line. Crease the diagonal fold. Repeat for the left top corner.

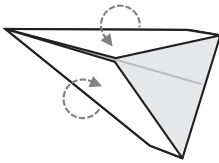

3 Fold the new right top corner to the centre line. Crease the folded end. Repeat for the new left top corner.

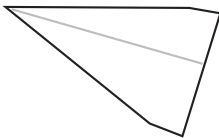

4 Turn the aeroplane over and fold the sheet lengthwise, inward, along the centre line. Crease the folded end.

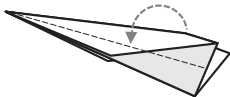

5 Fold the top flap down so that its front touches the bottom of the 'plane'. Crease the folded end.



6 Turn the paper over, fold and crease the other flap as you did in step 5.



7 Lift the flaps to create the wings.

a Now that you have made a paper aeroplane, work in a small group to see who can throw their plane the furthest. Every time one of your group flies their aeroplane, place the string from the starting position to where it lands. Cut the string to the exact measurement and place it next to a metre ruler to work out the distance. Record your distances in the table below:

Name	Distance in centimetres	Distance in metres

b Whose aeroplane went the furthest? _____

Units of length – millimetres

We use metres, centimetres and millimetres regularly in everyday life.
You should learn these millimetre facts:

1 centimetre = 10 millimetres

$$1 \text{ cm} = 10 \text{ mm}$$

$$45 \text{ mm} = 4 \text{ cm } 5 \text{ mm}$$

$$45 \text{ mm} = 4.5 \text{ cm}$$

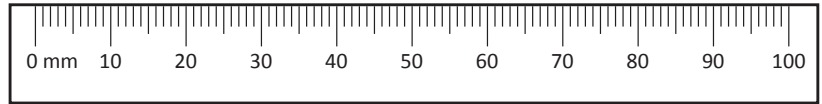

1 Estimate and measure these objects in millimetres:

	Object	Estimate	Millimetres
a	Width of your thumb		
b	Length of your hand		
c	Length of a grape		

2 Convert these centimetre measurements into millimetres:

a $4 \text{ cm} = \square \text{ mm}$ b $3 \text{ cm} = \square \text{ mm}$ c $10 \text{ cm} = \square \text{ mm}$

d $6\frac{1}{2} \text{ cm} = \square \text{ mm}$ e $7 \text{ cm} = \square \text{ mm}$ f $\frac{1}{2} \text{ cm} = \square \text{ mm}$

3 Write these as centimetres and millimetres:

a $17 \text{ mm} = \square \text{ cm } \square \text{ mm}$ b $29 \text{ mm} = \square \text{ cm } \square \text{ mm}$

c $42 \text{ mm} = \square \text{ cm } \square \text{ mm}$ d $36 \text{ mm} = \square \text{ cm } \square \text{ mm}$

4 Write these measurements as centimetres:

a $12 \text{ mm} = \square \text{ cm}$ b $46 \text{ mm} = \square \text{ cm}$

c $63 \text{ mm} = \square \text{ cm}$ d $48 \text{ mm} = \square \text{ cm}$

Units of length – millimetres

5 Follow these steps to measure these lines accurately in centimetres and millimetres.

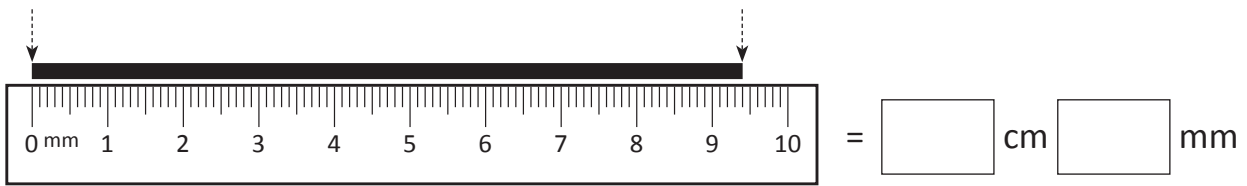

- Line up the zero on your ruler with the start of the line.
- Read the last cm that is at the end of the line.
- Write down the cm number.
- Count the mm after the cm and write it next to the cm.

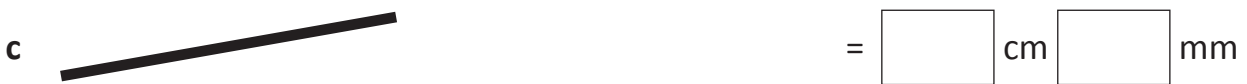

6 Complete the table for these deadly spiders:

		Length in mm	Length in cm and mm	Length in cm
a	Redback			0.7 cm
b	Funnel web		1 cm and 5 mm	
c	Black widow	13 mm		
d	Brown recluse			2.5 cm

e List these deadly spiders in order from smallest to largest:

Units of length – kilometres

Kilometres, metres, centimetres and millimetres are units of measurement in the metric system. The largest metric unit of length is the kilometre.

$$1 \text{ kilometre (km)} = 1000 \text{ metres (m)}$$

1 Convert these metre measurements into kilometres:

a 2000 m =

b 6000 m =

c 32 000 m =

d 87 000 m =

e 7500 m =

f 21 250 m =

g 5340 m =

h 69 730 m =

2 Put these metre and kilometre measurements in order, from longest to shortest:

20 300 m 23.22 km 22.03 km 22 300 km 23.2 km

3 Solve these word problems:

a Jo's family drove down to south of France on holiday. They drove 332 km on the first day, 278 km on the second day and 464 km on the third day. What was the total distance?

b An athlete is running a 10 000 m race. After 15 minutes he has run 5340 metres. How far does he still have to run in kilometres?

Convert it

apply



Getting ready

This is a game for two players. Players need a counter each, a copy of this page and a die.



copy



What to do

The object of this game is to get to the finish line first. Decide who will go first. That player rolls the die and moves that many spaces on the board. If you land on a measurement that is white, you must convert cm to mm OR m to cm. If you land on a measurement that is grey, you must either convert mm to cm OR cm to m. The other players decide if you are correct. If you are, then you move forward 1 space. If you are incorrect, you move backwards 2 spaces.

73	74 $\frac{1}{2}$ cm	75	76 20 cm	77 9.5 m	78	79	80	81 Finish
72	71 150 mm	70	69 7.25 m	68	67	66 7500 cm	65	64
55 30 cm	56	57	58 350 mm	59	60 0.75 m	61	62	63 $\frac{1}{2}$ m
54	53 5500 cm	52 16 cm 4 mm	51	50	49 35 cm	48	47	46 920 mm
37 980 mm	38	39 10 cm	40	41	42	43 10.6 cm	44	45 15 cm 2 mm
36	35 250 mm	34	33 75 mm	32 110 mm	31	30	29	28 500 mm
19	20 1000 cm	21	22 $\frac{3}{4}$ m	23	24	25 $2\frac{3}{4}$ m	26	27 660 mm
18 350 mm	17	16 $5\frac{1}{2}$ cm	15	14 $1\frac{1}{2}$ m	13	12	11 150 cm	10
1 Start	2	3 3 cm	4	5 100 mm	6	7 5 m	8	9 300 cm

Perimeter – measuring shapes

Perimeter is the total length around the outside of an enclosed space.
To find the perimeter of this shape, we add the lengths of all the sides.

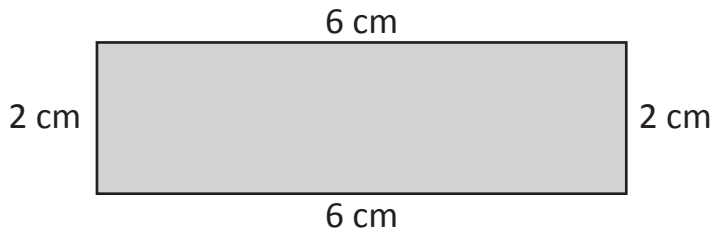

$$P = 6 + 2 + 6 + 2$$
$$= 16 \text{ cm}$$

1 Find the perimeters of these shapes:

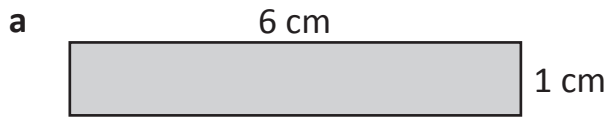

$$P = _ + _ + _ + _$$
$$= _ \text{ cm}$$

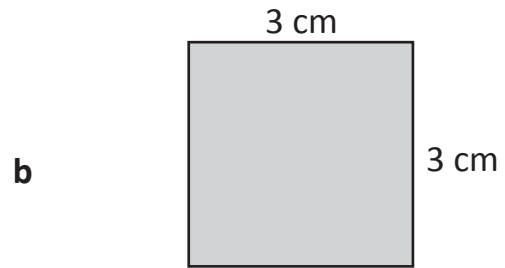

$$P = _ + _ + _ + _$$
$$= _ \text{ cm}$$

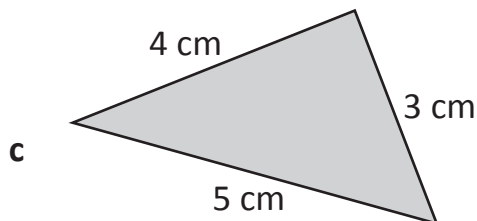

$$P = _ + _ + _$$
$$= _ \text{ cm}$$

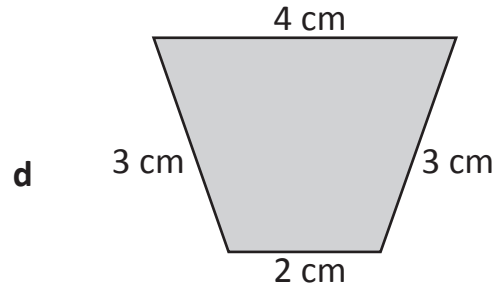

$$P = _ + _ + _ + _$$
$$= _ \text{ cm}$$

2 Find the perimeter of this shape. Set your working out clearly.

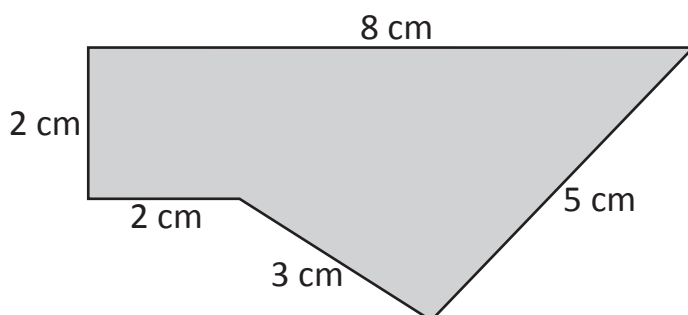

Perimeter – measuring shapes

3 Find the perimeters of these irregular shapes. Use the 1 cm dot paper as your guide.

a

P = _____

b

P = _____

c

P = _____

d

P = _____

e

P = _____

f

P = _____

4 Use a ruler to draw some shapes with the following perimeters. You can experiment first with a geoboard and some rubber bands.

a Draw a rectangle with a perimeter of 12 cm.

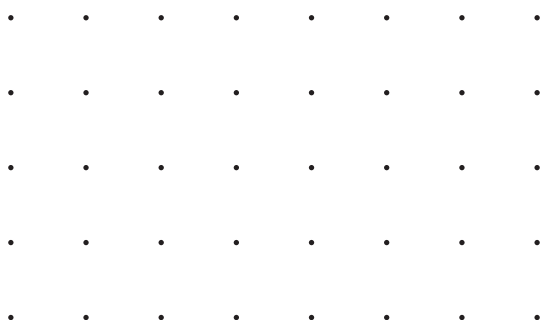

b Draw a rectangle with a perimeter of 20 cm.

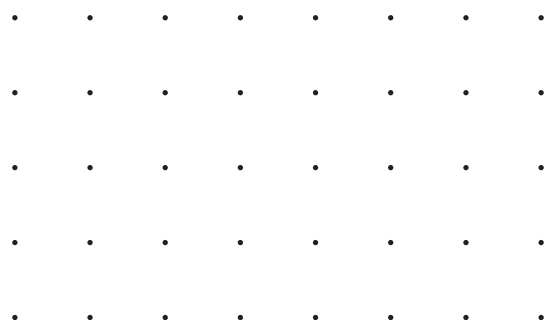

Perimeter – calculating perimeter

- 1 Use what you know about squares and rectangles to work out the perimeter of these shapes. Measuring will not help because they are not to scale. Look carefully at the dimensions.

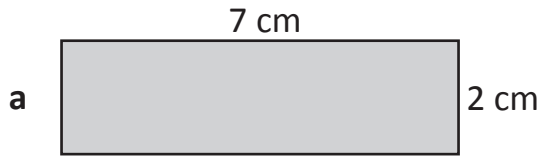

P = cm

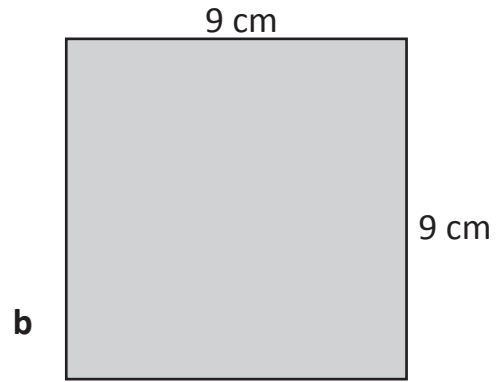

P = cm

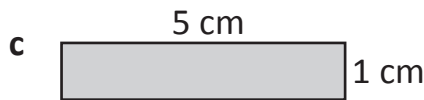

P = cm

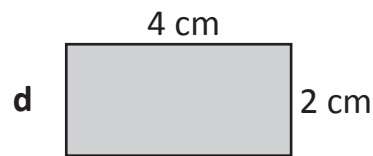

P = cm

- 2 Show how to find the perimeter of these shapes with an addition sentence and a multiplication sentence for each. Shape A has been done for you.

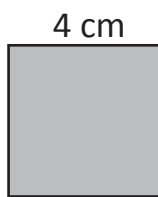

Shape A

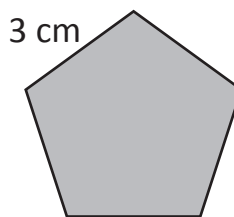

Shape B

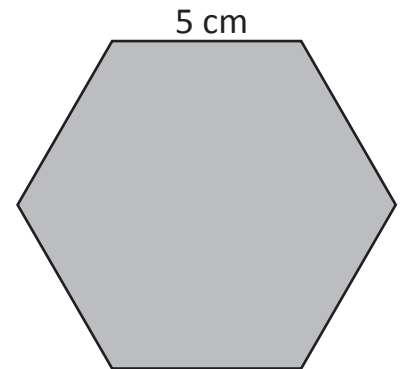

Shape C

Shape	Perimeter by addition	Perimeter by multiplication
A	$4 + 4 + 4 + 4 = 16 \text{ cm}$	$4 \text{ sides} \times 4 \text{ cm} = 16 \text{ cm}$
B		
C		

Perimeter – calculating perimeter

3 Predict the perimeter of each of these shapes on the square centimetre grid below. Show what the perimeter is by drawing and labelling.

a A square with 4 cm sides.

P = cm

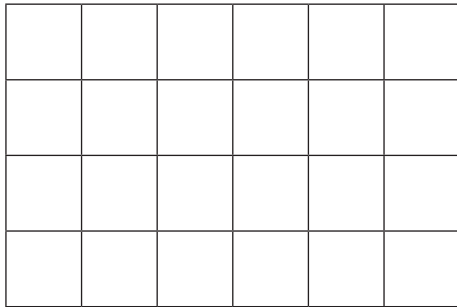

b A rectangle with two 3 cm sides and two 1 cm sides.

P = cm

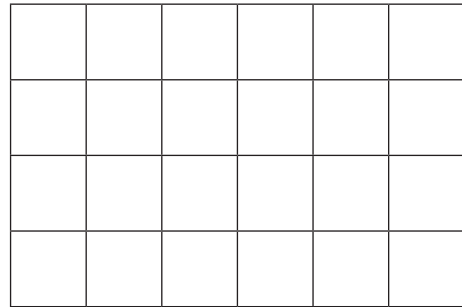

4 Use the 1 cm grid paper to construct the following shapes at each starting point with the stated perimeter.

a 10 cm



b 14 cm



c 8 cm

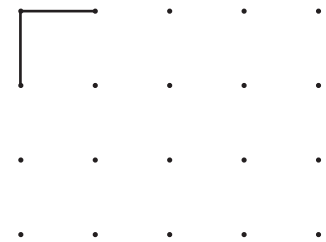

5 Here are more square centimetre grids.

a What is the perimeter of this irregular shape?

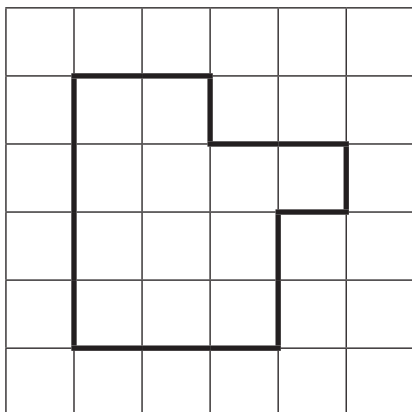

P = cm

b Draw a square with the same perimeter.

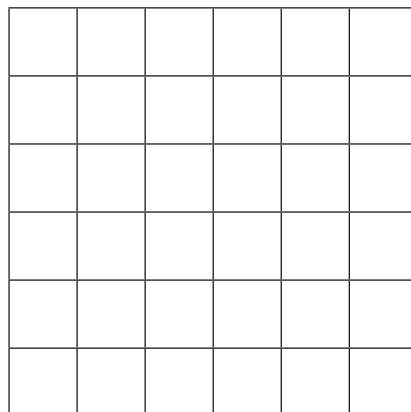

Perimeter – perimeter word problems

1 Solve these perimeter problems:

- a Pablo drew a rectangle in his workbook. The perimeter of the rectangle was 34 cm. Two sides are 12 cm long. How long are the other two sides?

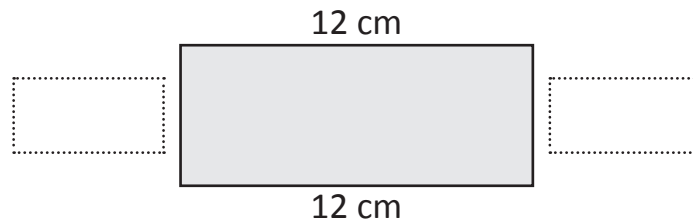

- b The perimeter of a square shaped pool is 100 m. What are the measurements of the pool?

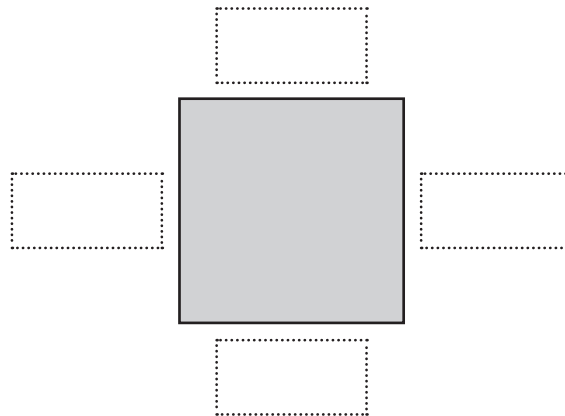

- c West Thyme Primary School is adding a new fence around the outside of the playground. The playground is rectangular shaped. One length is 16 m. The perimeter is 52 m. What are all the measurements of the playground?

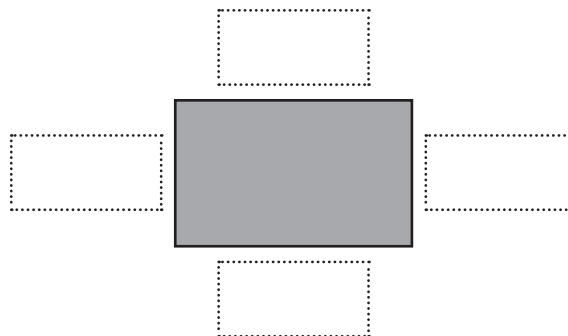

- d Liam made a pentagon from magnetic sticks. If the perimeter of his shape is 55 cm, what is the length of one side?

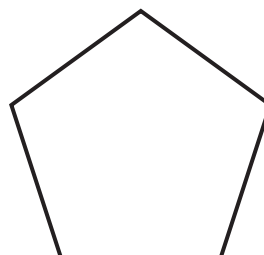

Length of one side =



What to do

Try these perimeter challenges:

- a The perimeter of this square is 32 cm.
When it is cut in half, we get two identical rectangles.
What is the perimeter of one rectangle?

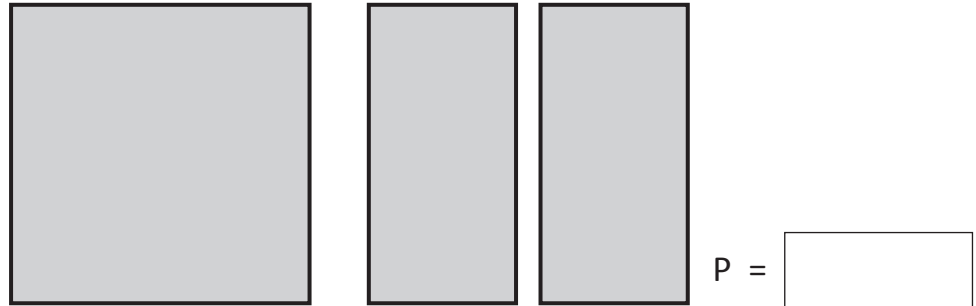

- b This rectangle is 6 cm wide.
How long is it if the perimeter is 32 cm?

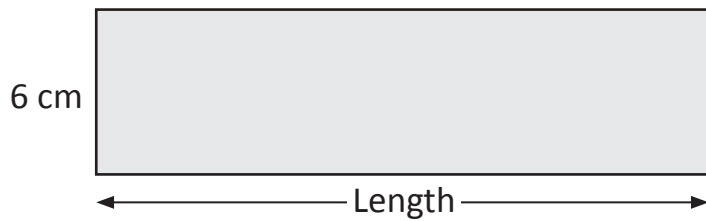

The lines on some of the sides are to show you they are all the same length.



THINK

- c Find the perimeter of this shape if the length is 12 cm.

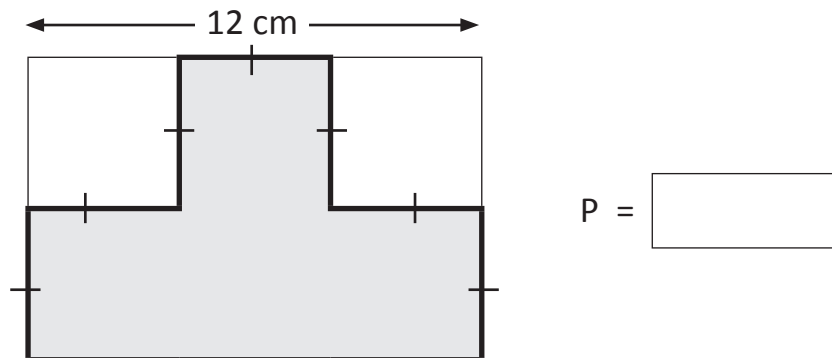



What to do

Use the clues in each of these diagrams to find the perimeter.

Diagram 1

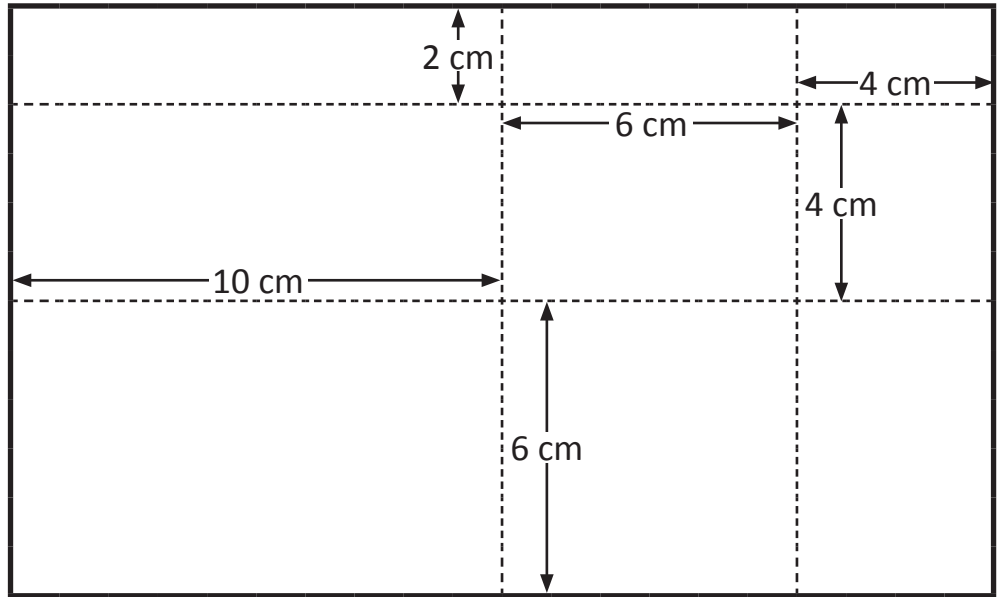

Perimeter =

Diagram 2

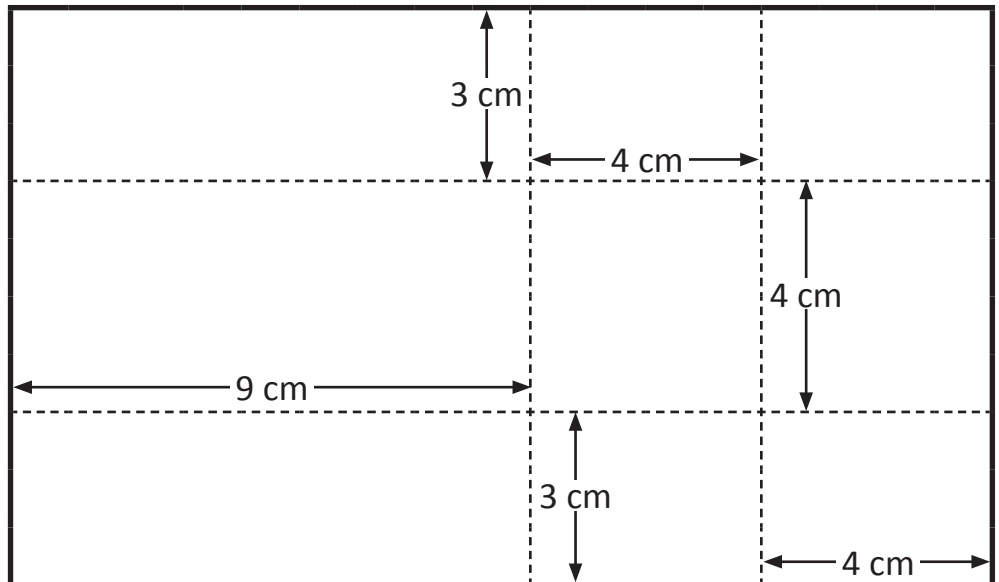

Perimeter =

Area – square centimetres

An area is the amount of surface on a shape or object.
 Small areas are measured in square centimetres.
 We write this as cm^2 for short.

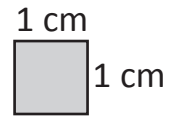

1 Calculate the area of each of the following shapes by counting the square centimetres.*

a	b	c
<input type="text"/> cm^2	<input type="text"/> cm^2	<input type="text"/> cm^2

d	e	f
<input type="text"/> cm^2	<input type="text"/> cm^2	<input type="text"/> cm^2

g	h
<input type="text"/> cm^2	<input type="text"/> cm^2

**Not drawn to scale.*

2 Using the grid paper below, create 4 different shapes that have an area of 6 cm^2 .*

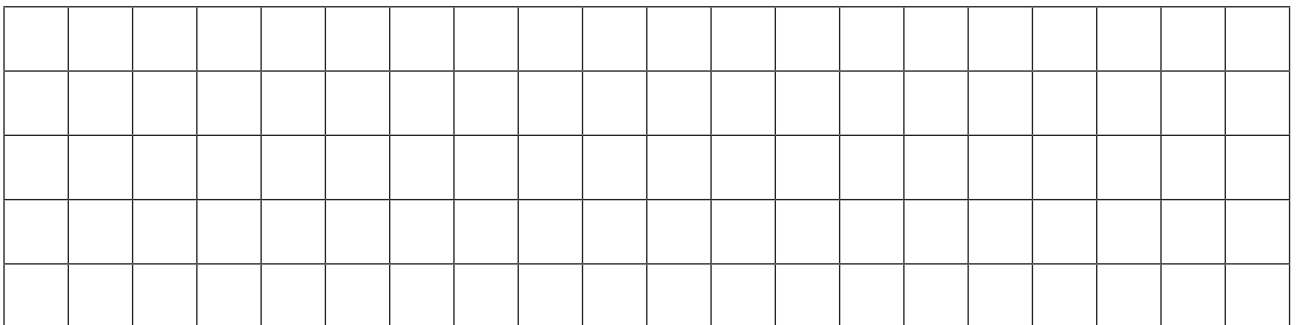

**Not drawn to scale.*

Area – square centimetres

3 Count the square centimetres that each shape is made up of.

a

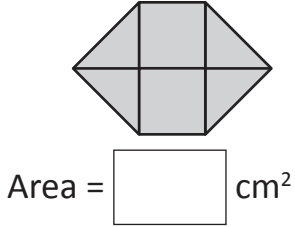

b

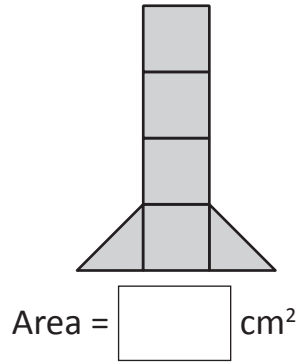

c

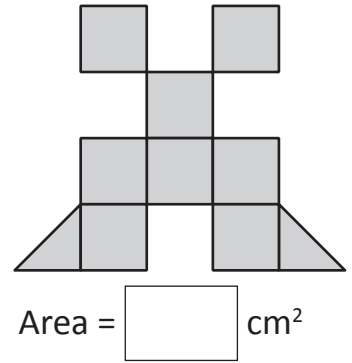

4 Measure the area of your hand on the grid below by counting how many squares it takes up. Is it easier to measure with your fingers stretched out or together?

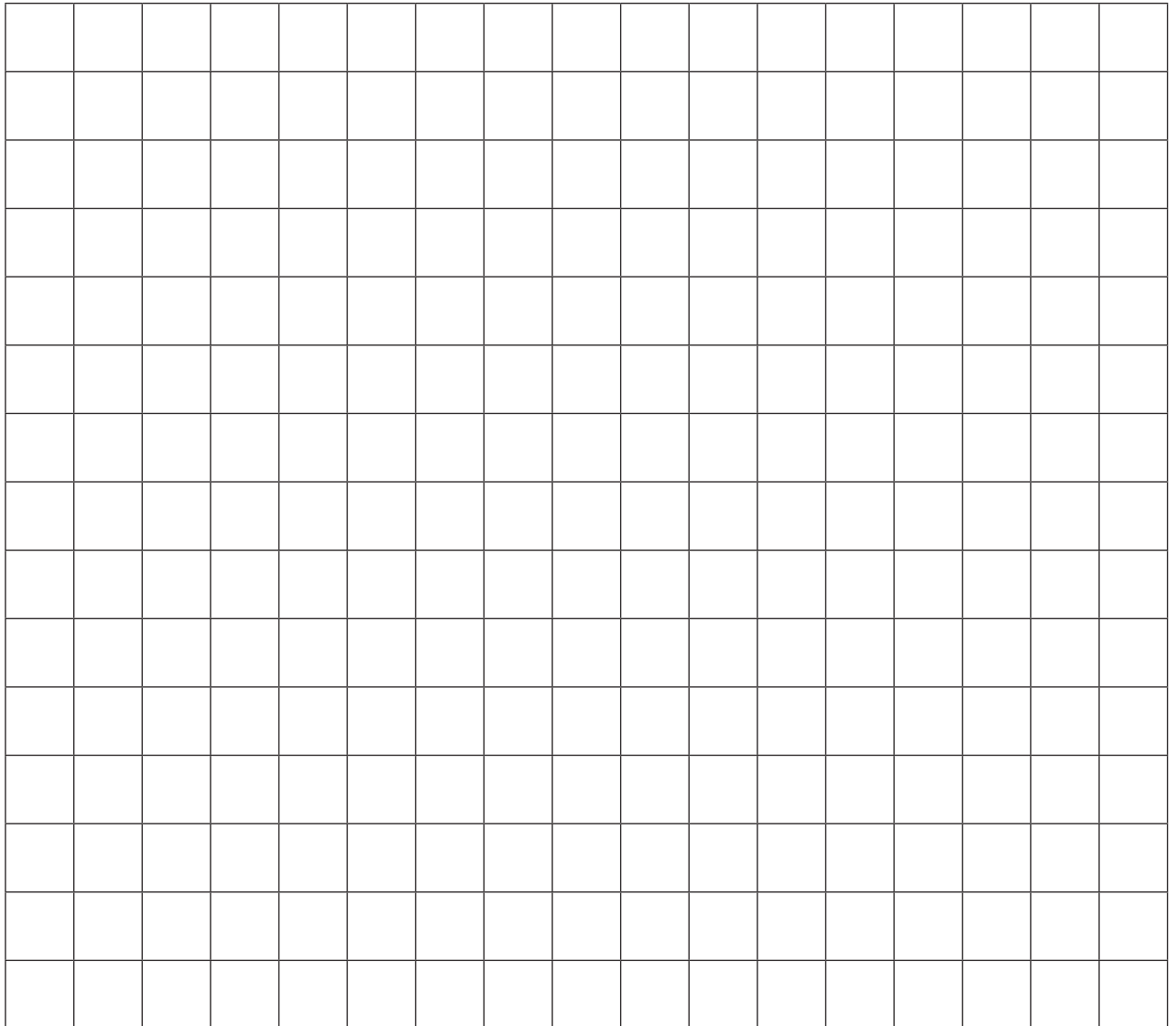

My hand is square centimetres.

Area – square centimetres

- 5 Use the 1 square centimetre grid paper to shade some irregular shapes with the following areas:

a 4 square centimetres

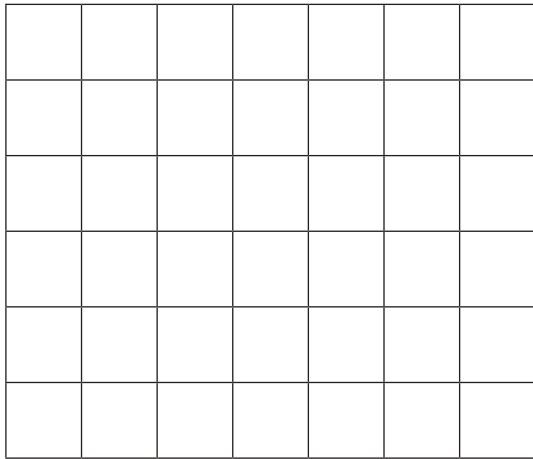

b 6 square centimetres

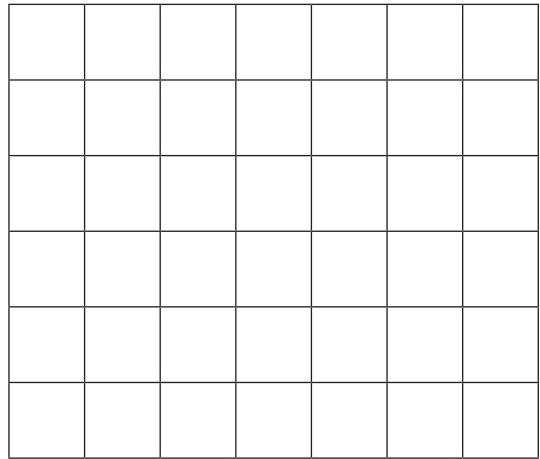

- 6 How many shapes can you make with an area of 9 square centimetres? Show them on the grid below. The first one has been done for you.

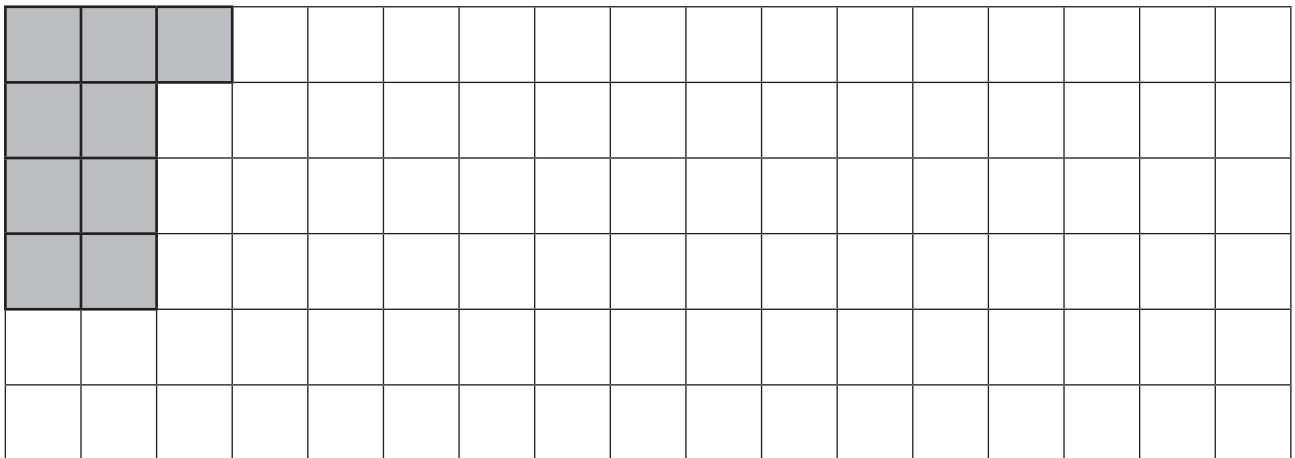

- 7 What is the area of each rectangle? Each square in the grid has an area of 1 cm².

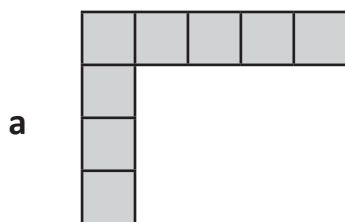

Area = _____

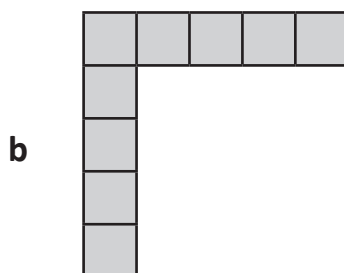

Area = _____

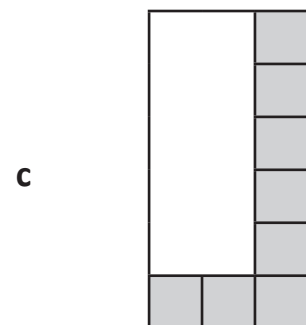

Area = _____

Area – investigating area and perimeter

1 What is the area and perimeter of these shapes?

a $P = \underline{\hspace{2cm}}$
 $A = \underline{\hspace{2cm}}$

b $P = \underline{\hspace{2cm}}$
 $A = \underline{\hspace{2cm}}$

c $P = \underline{\hspace{2cm}}$
 $A = \underline{\hspace{2cm}}$

d $P = \underline{\hspace{2cm}}$
 $A = \underline{\hspace{2cm}}$

1 cm
1 cm

2 Use the grid below to draw two shapes with a perimeter of 12 cm but with different areas:

1 cm
1 cm

3 Colour a square with a side length of 4 cm. Label its area and perimeter. Now colour a square with a side length of 5 cm and label its area and perimeter.

What do you notice? _____



What to do

Solve these area challenges based on the dimensions:

- a A framed photograph is $16\text{ cm} \times 25\text{ cm}$. The frame itself is 5 cm wide. Use these clues to find the area of the photograph inside the frame.

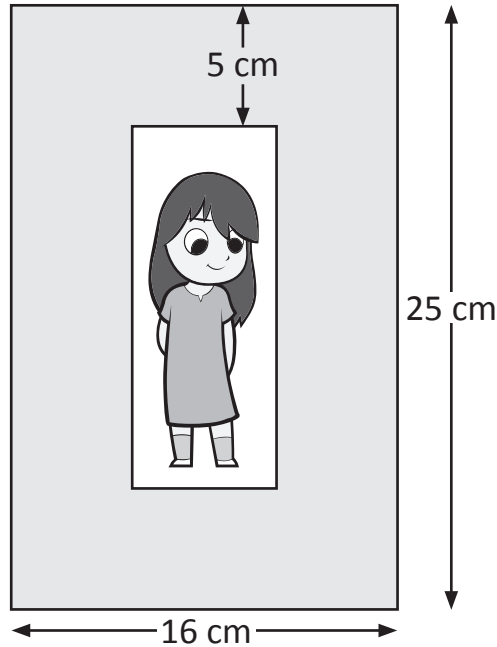

The area of the photograph is _____ cm^2 .

.....

- b Using a ruler, copy this shape so it reflects on the right of the mirror line. Then work out the total area of this shape.

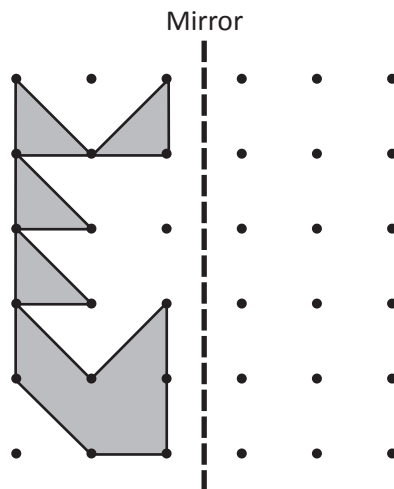

The total area of this shape is _____ cm^2 .



Solve these area challenges based on the dimensions:

- a Max folded a rectangular piece of paper in half three times to make a square. If one side of the final square was 2 cm, what was the area of the piece of paper he started with?

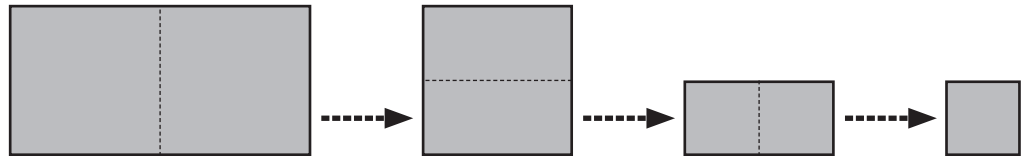

The area of the piece of paper he started with was _____ cm^2 .

.....

- b Amber received a drawing from her cousin Cameron. The drawing was on a square piece of paper folded in half four times. If the area of the folded drawing was 4 cm^2 , what was the area of the original piece of paper that Cameron drew on?

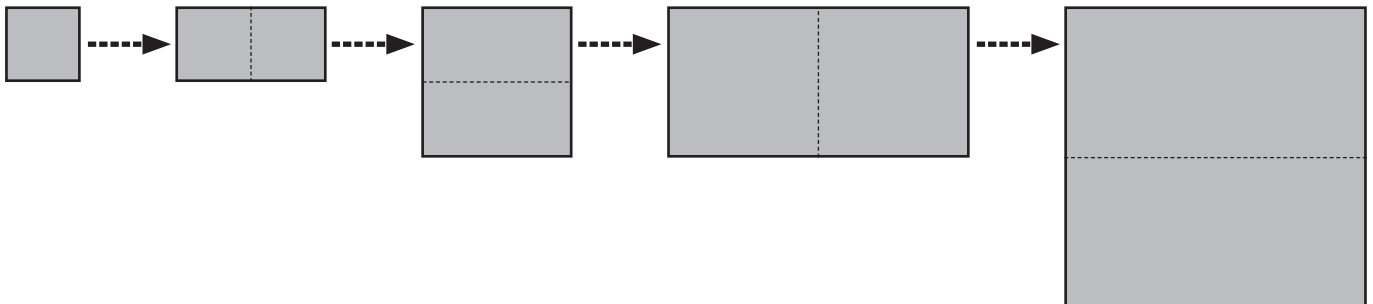

The area of the original piece of paper that Cameron drew on was _____ cm^2 .